

Please display "Identification Marks"

The purpose of the identification markings is to facilitate the sorting of discarded items by consumers when they put out the waste and to promote selective collection by municipalities. Based on the Resource Effective Use Promotion Law (official name: Law Concerning Promotion of Effective Use of Resources) before its revision, there has already been an obligation to display identification marks on steel or aluminum cans for alcoholic or non-alcoholic beverages and PET bottles for alcoholic, non-alcoholic beverages or soy sauce, but from April 2001, this obligation has been extended to plastic and paper containers and wrapping.

			PET bottles for beverages and soy sauce
			Steel can for beverages
			Aluminum can for beverages
			Plastic containers and wrapping, excluding above PET bottles for beverages and soy sauce
			Paper containers and wrapping, excluding paper drink packs (using no aluminum) and corrugated cardboard

Business Entities Subject to the Law, and Targeted Containers and Wrapping

- Business entities using containers or wrapping, business entities manufacturing containers or wrapping and business entities importing and selling containers or wrapping bear the Identification Marking obligation.
- Note that even small-sized business entities, unlike in the case of recycling obligation, are not exempt from the Identification Marking obligation.
- Recycling obligation and Identification Marking obligation, as a general rule, do not apply to containers and wrapping of merchandise consumed for the purpose of business activities.

▼ For inquiries regarding Identification Markings...

	TEL	FAX	Homepage
Ministry of Economy, Trade and Industry: Industrial Science and Technology Policy and Environment Bureau, Recycling Promotion Division	03-3501-4978		http://www.meti.go.jp/
Designated Organization Japan Containers and Packaging Recycling Association: Research and Planning Division	03-5532-8591 / 8558	03-5532-9698	http://www.jppra.or.jp/
Printing Pattern Plastic Containers and Packaging Recycling Promotion Council	03-3501-5893	03-5521-9018	http://www.pprc.gr.jp/
Paper Containers and Packaging Recycling Promotion Council	03-3501-6191	03-3501-0203	http://www.kami-suisinkyo.org/
Plastic Material Indication for Plastic Packaging Japan Plastic Industries Federation	03-3586-9761	03-3586-9760	http://www.jpif.gr.jp/
Voluntary Marking Paper Drink Packs Council	03-3264-3903	03-3261-9176	
Corrugated Cardboard Recycling Council	03-3248-4851	03-5550-2101	
Markings for Steel or Aluminum Cans and PET Bottles Steel Can Recycling Association	03-5550-9431	03-5550-9435	http://www.rts.or.jp/steelcan/
Aluminum Cans Recycling Association	03-3582-9755	03-3505-1750	http://www.alumi-can.or.jp/
PET Bottles Recycling Promotion Council	03-3662-7591	03-5623-2885	http://www.petbottle-rec.gr.jp/

Method of Identification Markings (plastic marking and paper marking)

① Marking Rules

- **Design**
The design of the Identification Marks shall basically be as per the marks shown herein. As long as Marks remain easily recognizable and conspicuous, minor modification or decoration is allowed to the prescribed design.
- **Size**
The vertical length of the Identification Mark shall be:

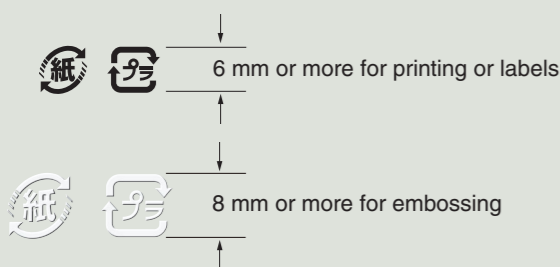

- **Marking Method**
Identification Marks shall be indicated on the surface by printing, embossing or labels.

② Multiple Packaging and Collective Marking

- In case of so-called multiple packaging which consists of separable components, such as cups for instant noodles (the cup, a lid, outer film and soup bag), or shampoo bottles (the bottle, cap and pump), or which consists of outer packaging and inner packaging contained therein, such as cake box (inner bag and outer box), each component (other components are called "integrated containers and wrapping" in the rules and regulations) is regarded to be one container or wrapping, and the Identification Mark shall basically be placed directly on each of them.
- However, the marks for respective components may be collectively placed on one of them if they are to be discarded at almost the same time. In this case, the names of components (called "role names" in the rules and regulations) shall be indicated near their respective Marks.

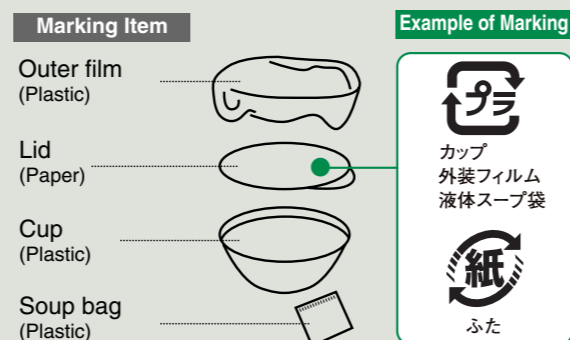

⑤ Wrapping Paper

- Wrapping paper (made of paper or plastic) to be used by retail stores is exempt from the Marking requirement if its size is 1,300 square centimeters or less. However, the Identification Marking is preferred even for such small sized paper if the cutting shape is known when the paper is ordered.
- Wrapping paper manufactured to wrap a specific merchandise is not exempted regardless of its size.

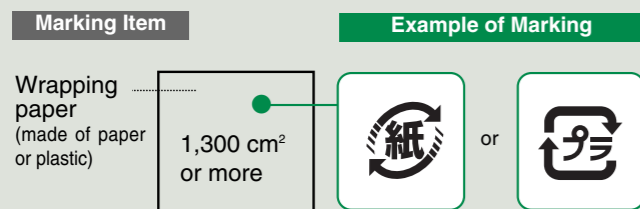

⑥ Imported Goods

- Importers assume the obligation of the Identification Markings in the following cases:
- They provide directions regarding specification of materials or structure of containers and wrapping or use of their trademarks.
 - Japanese language is used on containers and wrapping by printing, embossing or labels.

Penalties

Any entities designated as "indication identification entities" or that have the obligation to make identification markings that fail to make the necessary indications or comply with the specified requirements will be subject to government "penalties" through a process of guidance, public announcements, and injunctions in accordance with the provisions of the Law for the Promotion of Effective Utilization of Resources.
* Smaller enterprises as stipulated in the Small and Medium Enterprise Basic Law or designated by government ordinances will be not be the target of such guidance, if the amount of their receipts corresponds to government-designated requirements.

③ Composite Packaging

- In case of plastic spouts on paper packs of Japanese sake (which also contain aluminum) and paper labels glued on plastic bottles not separable from glass bottles, or laminated film of plastic and aluminum, the inseparable unit is regarded to be one container or wrapping. The Identification Mark to be placed on such a unit is decided by the heaviest material in the unit.
For example, for containers and wrapping made of plastic, aluminum and paper, if the plastic accounts for the most weight, they are considered primarily plastic packaging, and the plastic marking is displayed.
- However, the plastic shrink labels surrounding PET bottles used for beverages or soy sauce, many of which come with perforations to make it easy to remove them, are treated as a separable component in multiple packaging, as discussed ② on the left.

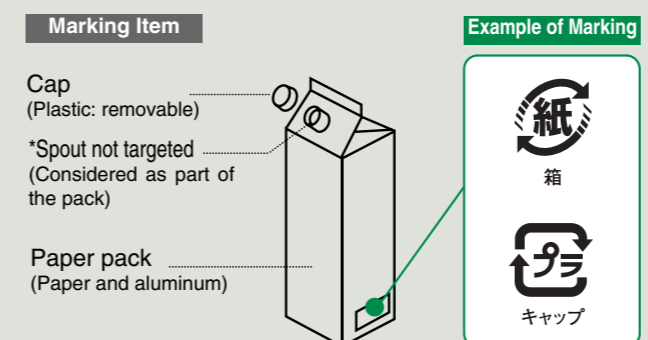

⑦ Material Indication

- Regarding plastic containers and wrapping, there is no legal obligation to indicate the type of plastic used or the presence of other materials, but it is still desirable to do so.
- Even when displaying them voluntarily, one must follow guidelines in JIS K 6899-1200 (ISO1043-1 1997) regarding symbols for materials.
- For composite materials, two or more materials are to be indicated, and the most prevalent material is to be underlined.
- A combined indication will have a colon separating the name of the role from the symbol for the material, as in the example below right.

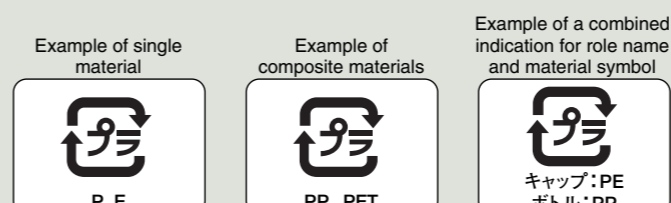

④ Plain Containers and Wrapping and Those on which Markings Cannot be Made

- Items on which labels have been glued or those made by a molding process in which it is possible to engrave markings do not qualify as plain.
- For plain containers and wrapping and those on which the marking is not physically possible but which come with other structural parts that can be removed (the "integrated containers and wrapping" of ② on the left) including one or more for which there is Identification Markings obligation (steel or aluminum beverage cans; beverages or soy sauce PET bottles; plastic or paper containers and wrapping: called "related containers and wrapping" in the rules and regulations), the Identification Marks along with the role name will be displayed on one of the "integrated containers and wrapping." In this case, if there is a piece of "integrated containers and wrapping" which will be discarded at almost the same time as the plain containers and wrapping, or that on which the marking is not physically possible, the marking will be displayed on that.
- If there are no "related containers and wrapping" among the other structural parts, or if there are, but they are all plain or cannot be marked on, there is no Identification Markings obligation.

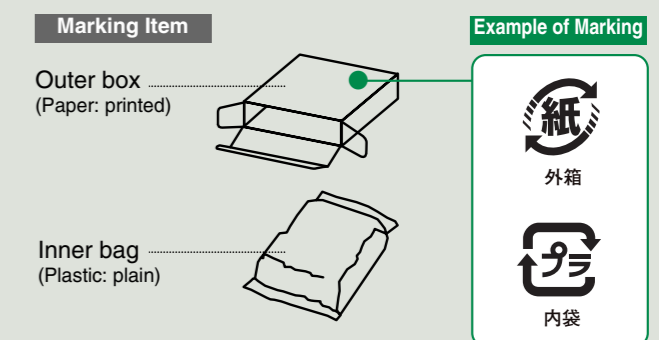

⑧ Marking Guidelines

- In order to facilitate implementation of Identification Markings, it is expected that industrial organizations establish guidelines for each industry and member companies follow these.

⑨ Voluntary Marking

- There is no legal obligation for Identification Markings for paper drink packs (not using aluminum) and corrugated cardboard packaging, but related industrial organizations have voluntarily adopted markings for these and are displaying them.

